

PREPARING FOR THE INSTALLATION OF YOUR PORTABLE SPA/HOT TUB



PREPARING FOR YOUR SPA

We hope the following will help prepare you before you take delivery of your spa.

Where to site the Spa/Hot Tub

Choose an area that will be suitable for you, remembering that you may need to be near a changing area, some privacy may be required, falling leaves may be a concern, and that the light/sunny areas are more suitable. Sheltered areas in the summer may become open during the winter. An area in front of your spa should be clear so that grass and debris are not transferred to the water. You know your garden.

Access

Firstly, you must ensure you have adequate access for the size of the spa you have chosen. Please note: The dimensions listed in the brochure are the total outer dimensions of the spa + or – 3% also allow 5mm(1/4”) for packaging.

Check the widths/heights of doorways; passages and gates to make sure the spa can pass. Gates, fences and doors may need to be removed (prior to delivery).

Make sure that there is nothing protruding such as drainage pipes or sills that could obstruct the way.

Check to see if there are any low roofs or branches that would hinder vertical clearance. If there are any corners on the path to your designated installation site, check to see the spa will pass.

The route to where the spa is to be sited should be flat and level and not soft ground. Check and inform us if there are any slopes, retaining walls, steps or differences in level that will cause problems. Any extra resources required will be charged in addition.

Under special circumstances, where there is no clear or easy route, a crane can be used to position your spa. Please contact us to arrange this service if you think it may be necessary. Please note that the cost of the crane will be extra.

Most spas are delivered on their sides on a specially made spa cart, (see picture). You must therefore make sure the access is big enough for the spa and the cart. Please bear in mind the height of the spa will increase slightly when on the cart by approximately 6 – 8 inches (150 – 200mm).

If access is through / across a neighbouring property / land you must seek permission, our installers will not proceed without your assurance that permission has been gained by you.

PLEASE NOTE – THE SPA CANNOT BE REMOVED FROM THE CART

PREPARING FOR YOUR SPA

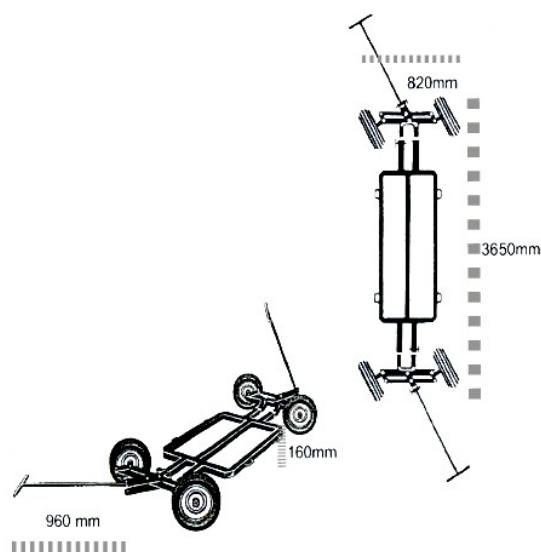

SPA CART

Small spas (spas under 1.9m x 1.9m x 750mm) may be delivered on a castor board. This enables the spa to be moved easily over perfectly level and hard ground (eg. level slabs, etc). **Please specify if this is required before delivery**. However, the ground leading to the spa must be very level and hard (i.e. slabs, concrete or macadam), as the castors will dig into soft ground.



The Base/Plinth

Wherever you decide to install your spa, it is essential that a solid foundation be provided. Grass is unsuitable. Please note: It is the responsibility of the customer to provide a suitable base that is flat, level and solid to prevent distortion from occurring. Any structural damage caused by improper installation (of spa base), on an inadequate foundation damage caused to a spa will not be covered under the manufacturer's warranty.

An ideal base would be concrete 4 – 6 inches (100 - 150mm) thick. However, existing patio slabs and block paving may be utilized but again must be flat, level and on a satisfactory sub base. All bases must be able to take the weight of the spa plus the water and occupants. No form levelling by means of chocks is accepted.

PREPARING FOR YOUR SPA

Service Access

Access is required around the spa for any future maintenance, ideally 24 inches (600mm). If this is not practical then the area should be of sufficient size so that the spa can be moved when empty of water for access. The front has to be accessed for routine maintenance.



Bases must be prepared in plenty of time prior to delivery, thus allowing time for the concrete, etc to fully cure.



Electrical Supply

A suitably qualified electrician e.g. NICEIC registered, must carry out all electrical work to the IEE latest standards. The electrical supply will be permanently connected (hardwired) to a single-phase 240V supply from the earth leakage protected consumer unit directly to a waterproof switch. A 3 core armoured cable connected and isolated to the waterproof switch is required, this must be left at the side (not underneath) spa, this cable must be at least 4 metres from the edge of the spa, for our installers to connect into the spa.

A Certificate of Approval (to Part P of the Building Regulations) will need to be produced. Failure to produce or to meet our terms will result in you spa not being connected to the electrics and we will be unable to commission the spa. The connection must be made at the consumer unit, as the installers will only connect at the spa end.

Please refer to your order form for the exact electrical requirements for your spa.

PREPARING FOR YOUR SPA

Water/Electrical Supply

A mains water supply with reasonable water pressure, connected to a garden hose must be provided by the customer to fill the spa. This should be flushed through to expel stale water. The hose can also be used to empty the spa when changing the water. A 240V power supply is required near within 10 metres of the base for lowering the spa.

Chemicals

A degree in chemistry is not required! A chemical starter pack will be supplied with your spa. The installers will explain the treatment required. They will also show you how to conduct the test with remedial actions. A spa water treatment manual will also be supplied with the spa.

Spa Controls

The spas all have digital controls and you will be shown how the main controls work by the installers. However an operation manual is supplied with the spa for you to be able to set the controls for your ease and comfort.

IMPORTANT NOTE:

Please be advised that aborted visits due to non-preparation of base, poor access unsuitable ground or obstacles, unsuitable electrical/water supply, etc are chargeable at the Company's hourly rate.

Manpower

We supply two people to install the spa on our spa cart.
They will NOT remove the spa from the cart.

If access is difficult, extra assistance by able bodied people will be required, which you will have to organize prior to the delivery.

If you are in any doubts with your access, we will be happy to arrange a site visit.

We hope this leaflet helps you prepare for your hot tub/portable spa.
If there are any questions or queries you may have, please ask us prior to delivery.

Unfortunately, we cannot advise on how to cope with the anticipation and excitement of owning a spa!

PREPARING FOR YOUR SPA

Spa Weights & Power Supply

| SPA | Dimensions | | Dry Weight Kgs | Water capacity | | Capacity Weight Kgs | Current Amps |
|---------------|-------------|-------------|-------------------|----------------|---------|------------------------|-----------------|
| | (mm) | (inches) | | Ltrs | Gallons | | |
| Glendale | 2310 x 1090 | 91" x 43" | 150 | 318 | 70 | 567 | 20 |
| | x 760 | x 30" | | | | | |
| Phoenix | 1860 x 1860 | 73" x 73" | 160 | 1035 | 230 | 1000 | 16 |
| | x 765 | x 30" | | | | | |
| Tucson | 2010 dia | 79" dia | 216 | 1137 | 250 | 1084 | 20 |
| | x 865 | x 34" | | | | | |
| Winslow | 2315 x 2315 | 91" x 91" | 290 | 1323 | 291 | 1615 | 32 |
| | x 870 | x 34" | | | | | |
| Tampa II | 2030 x 1880 | 80" x 74" | 215 | 1125 | 250 | 1305 | 16 |
| | x 790 | x 31" | | | | | |
| Key West II | 2060 x 1400 | 81" x 55" | 165 | 675 | 150 | 940 | 32 |
| | x 765 | x 30" | | | | | |
| Miami II | 2090 x 2010 | 79" x 77" | 280 | 1500 | 330 | 1650 | 25 |
| | x 940 | x 37" | | | | | |
| Coral Springs | 2315 x 2315 | 91" x 91" | 347 | 1323 | 291 | 1669 | 32 |
| | x 865 | 34" | | | | | |
| Orlando | 2315 x 2315 | 91" x 91" | 365 | 1323 | 291 | 1690 | 32 |
| | X 865 | 34" | | | | | |
| Boston | 2290 x 2120 | 90" x 83.5" | 375 | 1323 | 291 | 1701 | 32 |
| | X 940 | 37" | | | | | |
| Newhaven | 2315 x 2315 | 91" x 91" | 425 | 1437 | 316 | 1865 | 32 |
| | X 940 | 37" | | | | | |
| Bridgeport | 2315 x 2315 | 91" x 91" | 408 | 1437 | 316 | 1732 | 32 |
| | X 940 | 37" | | | | | |
| Springfield | 2365 x 2365 | 93" x 93" | 495 | 1591 | 350 | 2082 | 32 |
| | X 965 | 38" | | | | | |
| Manhattan | 2210 x 2210 | 87" x 87" | 408 | 1227 | 270 | 1637 | 32 |
| | X 940 | 37" | | | | | |

Please allow + or - 2% to stated dimensions